

PLAN SHOWING THE PROPOSED DWELLING HOUSE IN S. NO 33/1A35 ABDUL KALAM ASAD IIIrd STREET, ARIYANVAIAL, MINJUR TOWN PANCHAYAT, PONNERI TALUK, CHANGALPATTU DIST, FOR MR. GULAM MYDEEN

SCALE 1" = 8'-0" (1:60)

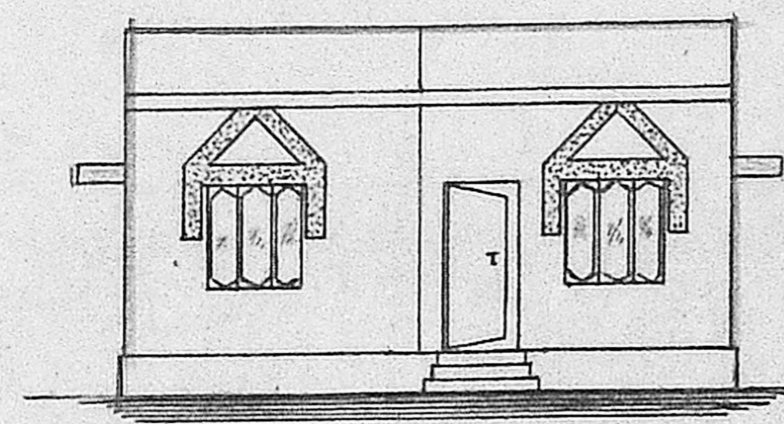

ELEVATION

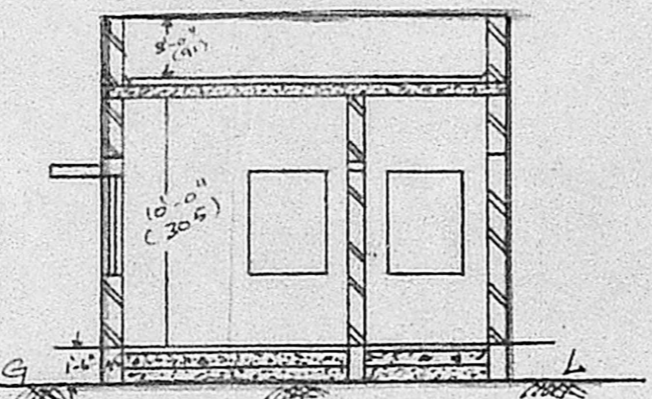

SECTION ON 'AA'

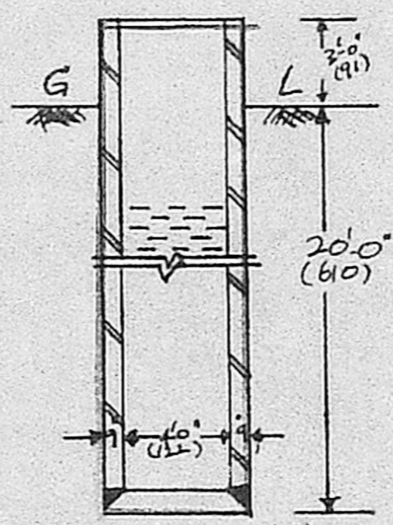

SECTION OF WELL

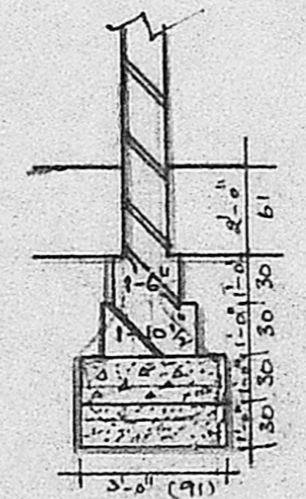

FOUNDATION DETAILS

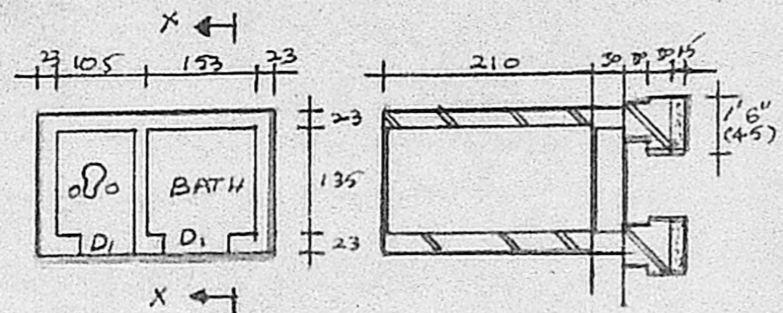

PLAN SECTION ON 'XX' DETAILS OF BATH & LAVATORY SCALE 1" = 8'-0" (1:60)

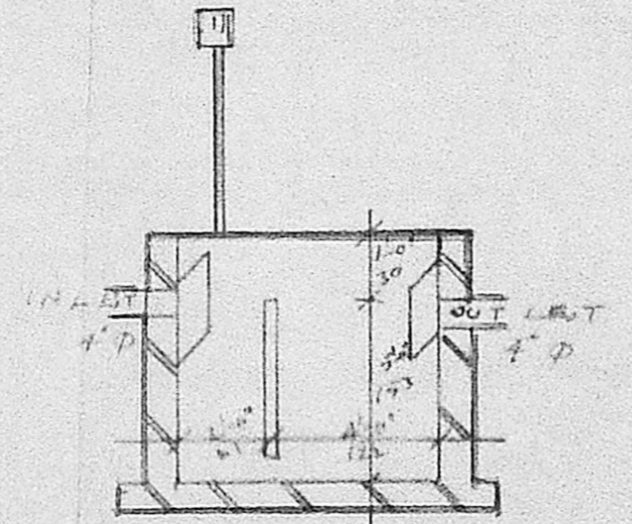

SECTION OF SEPTIC TANK

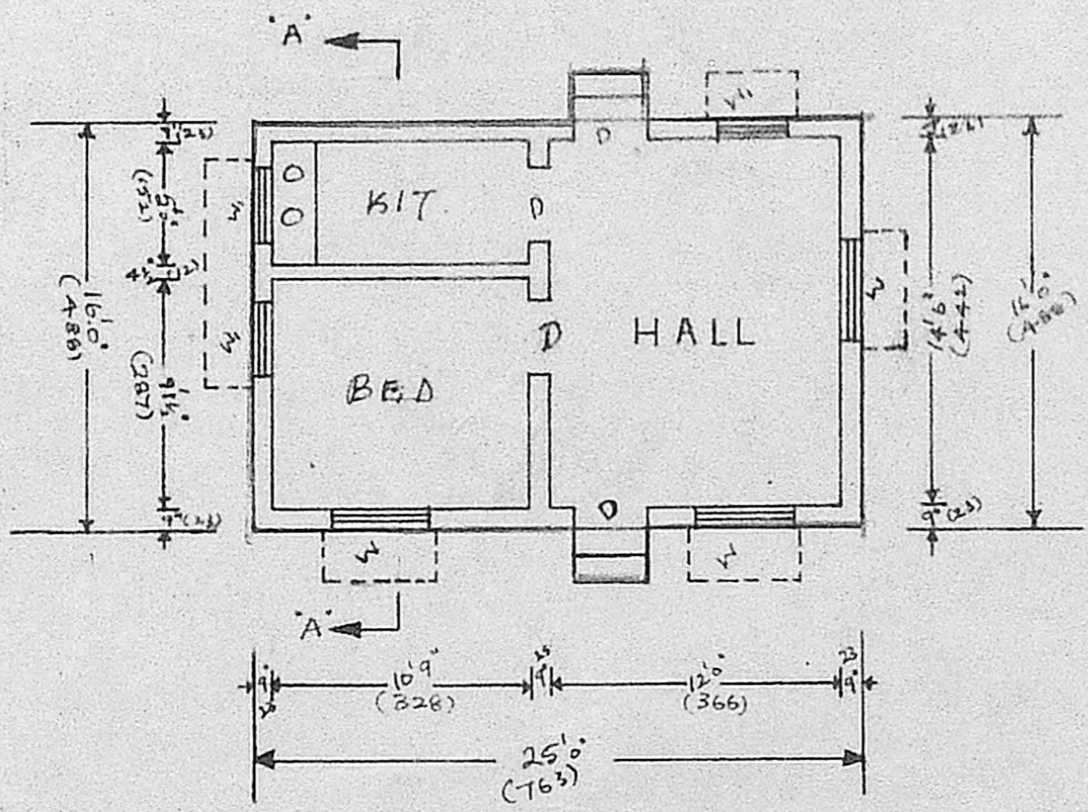

PLAN

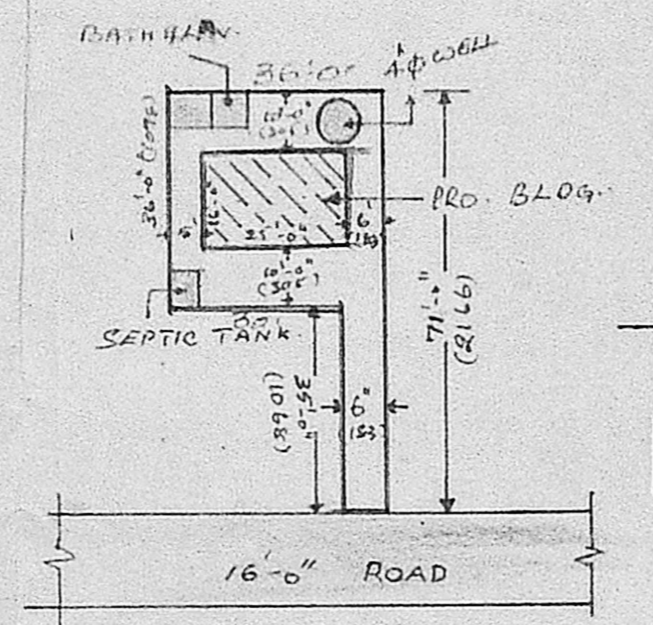

SITE PLAN SCALE 1" = 33'-0" (1:400)



APPROVED
 Subject to the conditions in this office letter.
 No. A/30/18/25/07/88
 J. L. [Signature]
 FOR MEMBER SECRETARY
 MADRAS METROPOLITAN
 DEVELOPMENT AUTHORITY
 25/12/88
 364-3" KATTUR ROAD
 NOT TO SCALE

SPECIFICATION	JOINERY DETAILS
1 CEMENT CONCRETE FOR FOUNDATION AND FLOORING (2) BRICK WORK IN CM 1:5 USING 1ST CLASS STOCK BRICKS.	D.T.W. Door 3'-0" x 7'-0"
(3) R.C.C. 1:2:4 FOR PLINTH BEAM, LINTEL SUNSHADE AND ROOF SLAB.	W.T.W. WINDOW 4'-0" x 4'-0"
(4) FLOOR FINISHING IN CM 1:3 20MM TK	W.T.W. -do- 3'-0" x 4'-0"
(5) PLASTERING IN CM 1:5 12MM TK.	PLINTH AREA : 37.23 M ²
	CARPET AREA : 30.58 M ²
	SITE AREA : 140.10 M ²

S. [Signature]
 OWNER

A. K. GURUVAIAH,
 LICENSE NO. [unclear]
 MINJUR TOWN PANCHAYAT,
 RES. 49/V, VELLALAR STREET,
 MINJUR-601 203.
 L. SURVEYOR

APPROVAL